

Crawler Type Aerial Platform

HX64B-2

APPLICATION & ATTACHMENT



6.38m Platform Height

- Wide working ranges
- Hydraulic pilot control system
- Travel Speed : 1.6 km/h
- Emissions Control Engine
- Low Noise Design



Operating panel designed for safety
(Upper control panel)

Notes : Photos include optional equipment. Some of the photos in this brochure show an unmanned machine with attachments in an operating position. These were taken for demonstration purposes only and the actions shown are not recommended under normal operating conditions.

WORKING RANGES

Unit: mm

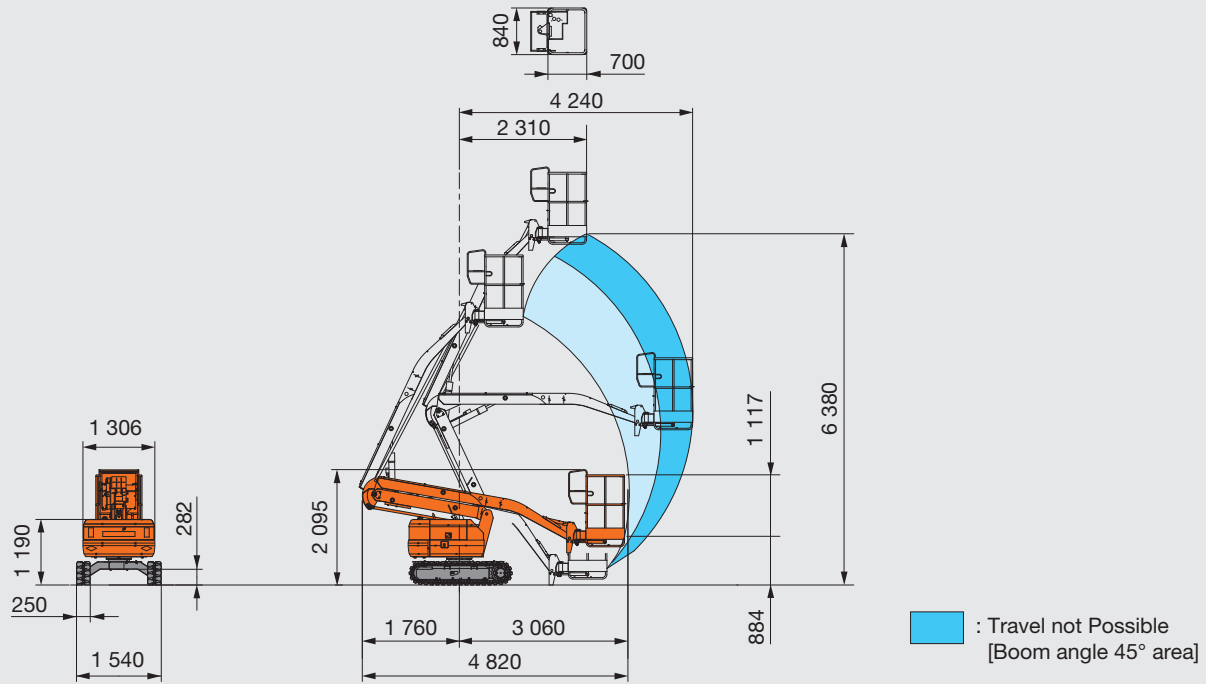

SPECIFICATIONS

Model		HX64B-2
Maximum work platform height	mm	6 380
Maximum horizontal reach	mm	4 240
Maximum allowable load	kg	150
Work platform turning angle	degree	Left 90 Right 45
Machine weight	kg	2 500
Shoe width	mm	250 (rubber shoes)
Speed		
Boom raise/lower	s	18.0 / 13.5
Arm Extend / Retract	s	15.0 / 13.5
Swing	min ⁻¹ (rpm)	1.1 (1.1)
Travel	km/h	1.6 / 0.8
Work platform turn	degree/s	135 / 15
Engine		
Model	Kubota D722-KA	
Type	Water-cooled, 3-cylinder swirl chamber	
Rated flywheel horsepower	kW/min ⁻¹ (PS/rpm)	8.8 / 2 300 (12 / 2 300)
Service refill capacities		
Fuel tank	L	30
Hydraulic oil tank	L	30

These specifications are subject to change without notice.

Illustrations and photos show the standard models, and may or may not include optional equipment, accessories, and all standard equipment with some differences in color and features.

Before use, read and understand the Operator's Manual for proper operation.